

Instrumentation to Study Startle Response of Primates

University of Wisconsin – Madison
College of Engineering
BME 301
May 3, 2001

Team Members:

(Mechanical Design Team)

Braden Rudolph
David Schmidt

(Software Design Team)

Matt Delisle
Corey Arnold

Client:

Andy Roberts
Assistant Professor
Department of Medical Physics

Advisor:

Professor Tompkins
College of Engineering

Abstract:

A recurring problem in animal psychology research is the inability to accurately quantify data. The current method involves the use of a human observer to record information related to the experiment. Unfortunately, this method is rife with human bias and error, thus causing inaccuracies in the recorded data. This problem is never more evident than in startle response experiments. Startle response experiments involve the startle, either by noise or light, of an animal and then quantifying the animal's movement afterwards. Our client, Andy Roberts, performs these experiments on rhesus monkeys and he faces the same problem of inaccurate data. Dr. Roberts came to us with his problem and outlined the specifications that he required. These included development of a device that could reliably, accurately and easily quantify both the startle response and general motion of the rhesus monkey. Two of the main restrictions for the device were that it must be used with the current cage design, while being non-distracting to the monkeys. Initially, the group considered multiple design possibilities including: Infrared cameras and sensors, strain gauges, and a force platform. After careful evaluation of the various aspects of each design and repeated consultation with related pundits, the final design was chosen. The final design involves the use of a force platform to quantify the movements of the primate in order to analyze the data and present it in a user-friendly format. The design entails the attachment of the force platform to the floor of the laboratory, and then the mechanical fastening of the cage to the force platform, consequently allowing the force platform to record the movements. The data is then manipulated using Visual Basic and Java programs to present the user with easy to read graphs and text fields.

Design Problem:

“The design and construction of a cage mount device for quantitation of startle, general motion, and activity of the rhesus monkey (Fig.1)” (Roberts 2000). The startle response is defined as: “A series of responses manifested when an individual [monkey] experiences a sudden frightening stimulus; this includes a tightening of muscles, changes in body stance, cardiovascular changes directed by the sympathetic nervous system, brain activity stimulation, and emotional excitement,” according to the Academic Press Dictionary of Science and Technology. The cage mount device must be out of the primate’s reach and non-distracting. The device must also be able to withstand the forces exerted by a 3 to 10 kilogram monkey in its cage (100.97 cm X 50.08 cm X 50.08 cm, Fig 2.). The device must be in compliance with the Wisconsin General Testing Apparatus (WGTA) and be contained within a simple soundproof room that the cage and monkey will also occupy.



Figure 1: Rhesus monkey, this species of monkey is used in the startle response experiment.



Figure 2: The cage where the monkey will be kept during the experiment.

Background:

A rare disorder in humans involves the inability to “relax” after being frightened or startled. These humans react much as healthy humans would when startled. They experience increased blood pressure, heart rate, and adrenaline levels. Unfortunately, they are unable to relax and lower these levels back to normal. Startle response research investigates the reactions of rhesus monkeys with this same disorder. Necessary information for this experiment includes accurate measurement of the movements of the rhesus monkey. Currently the method used for quantifying the movements of primates is to have undergraduate students observe and record their movements. This method is a tedious and time-consuming task with relatively inaccurate results. The purpose of our design is to eliminate the human error, and to develop a device that can produce accurate and repeatable results. This device must also fit with the current cages used and not disrupt the standard testing conditions. The testing of the primates is performed in cages that are located in a dark sound chamber.

Information Gathered:

The information we obtained from studying past startle response research indicated that past experiments had recorded animals’ startle response, but they had been performed on animals whose behavior was much more controllable than rhesus monkeys. In one example, the locomotion of crabs and other arthropods was successfully recorded by having the species walk across a force plate. The force platform for this experiment was successful in analyzing the movements of a 1/2-ounce crab. This example illustrates the high level of sensitivity displayed by current force platform models. The rhesus monkey is much larger and more erratic than a crab and requires a significant scaling up of the force platform design. Our attempts to find information on similar experiments involving primates were unsuccessful.

After reading about other experiments, we evaluated the restrictions for the device and came up with a few possible methods to record the monkey’s startle response. We considered using IR cameras, IR sensors, force platforms, and strain gauges. Additional sources for information recommended using infrared light emitters with a grid of Silicon Diode receptors. This system would need an 87-filter grid so that the transmitted IR light does not distract the monkey. It was suggested that other emitters and receptors would help aid in tracking the location and the locomotion of the monkey. The use of strain gauges on the bottom of the cage edges was also suggested to find the force that the primate is exerting on the cage (Webster, Appendix B). Upon further consultations, the use of a force plate would complete all of the tasks that need to be accomplished (Radwin). Bill Hagquist was contacted to discuss aspects of the mechanical side of the project. All of the ideas that were proposed to the group were taken into serious consideration when deciding the final design.

Design Criteria:

The system must meet the following design criteria:

- Measure forces exerted by the primate vs. time
- Quantify motions of the primate vs. time
- Withstand forces exerted by a 3-10 kg monkey
- Must not be distracting to the primate, out of sight and out of reach
- User friendly, easy to operate, calibrate, and distinguish data
- Interface with a computer for data manipulation, and control
- High sensitivity, repeatability, low-cross talk
- Must function in absence of light and confinements of sound testing chamber

Possible Solutions:

Idea #1 (IR Shell and Strain Gauge)

The first idea is to measure the monkey's force in the z-direction by four strain gauges and measure its position by use of two floodlights and a complimentary array of receptors. Each of the four strain gauges is placed on separate legs of the cage. One floodlight is located parallel to the x-axis of the cage, while the other floodlight is placed parallel to the y-axis of the cage, each one opposite to its complimentary array of infrared (IR) receptors. The four readings of each strain gauge are added together to get the total force created by the rhesus monkey. The floodlights and the IR receptors are mounted on a rectangular box that would enclose the cage. These two sets of receptors will give the monkeys position in the x, y, and z directions.

Advantages: The current cage configuration does not have to be altered. Sensors and the floodlight are not distracting to the monkey. This design is flexible because multiple transformations of the data can be calculated, such as: position, velocity, and acceleration in all three directions and the force in the z-direction. Also, the precision of the monkey's location can be adjusted depending on the clients needs.

Disadvantages: This design is complicated and gives unnecessary information. The shell enclosing the cage will probably ruin startle experiments using flashing lights.

Idea #2 (IR Motion Sensor and Force Transducers)

The second idea involves the use of four piezoelectric force transducers to measure force in the z-direction and an IR motion sensor to detect quick movements created by startle response. The IR motion sensor is located above the cage, while a transducer is incorporated in each leg. The motion sensor is set to detect motion at or above a certain designated velocity, the determining velocity, in order to record only startle response motions. The four signals given by each transducer are summed together to give the total force in the z-direction.

Advantages: This design is relatively inexpensive, while still giving the necessary data. The overall design is discrete and not distracting to the monkey.

Disadvantages: The cage has to be altered since the force transducers must be incorporated into the legs of the cage. Another problem arises if there is any discrepancy of the transducer alignment, which will result in inaccurate data. Also, choosing the determining velocity is very unscientific because there is no way to differentiate between velocities created by startle response and general motion.

Idea #3 (IR Arrays and Strain Gauges)

The third alternative design consists of four strain gauges and multiple IR emitters and their receptors located on two sets of arrays. The strain gauges are located on each leg of the existing cage configuration. The signals from each the four strain gauges are be summed together to calculate the total force of the monkey in the z-direction. Each IR array consists of hundreds of emitters or receptors ordered in a grid-like fashion. The array that consists of emitters is attached to the wall of the sound chamber while its complimentary receptor array is located on the opposite wall. One set of arrays measures the monkeys position in the x-z plane, while the other set measures the monkey's position in the y-z plane.

Advantages: This design will calculate the position, velocity, and acceleration of the monkey precisely and accurately in all three directions.

Disadvantages: The design is expensive and very complicated to build and maintain because the emitters, receptors, and cage have to be perfectly aligned.

Force Platform System (Chosen Design):

The design chosen to most accurately measure the actions and startle responses of the primate was that of the force platform system. With the use of a force platform, we will be able to measure the ground reaction forces and moments produced by the primate. Three orthogonal forces (x, y, and z) and their respected moments will be measured with the center of the platform as the origin. From the platform, the data is output to an Excel file that displays the specified columns of data. The possible output data consists of forces in the x, y and z-axis along with the moments along the x, y and z-axis.

Our design will make use of the force in the z direction and the moments measured in the x and y directions. Force versus time will be graphed to quantify the vertical movement of the primate. Furthermore, two graphs will be produced using the center of pressure calculation. In order to calculate the center of pressure, the moment in the x direction is divided by the force (z) at that instance to get the y coordinate of the center of pressure and the moment in the y direction is measure by the force (z) to get the x coordinate. (Calculations shown below)

- $F = \text{Force (z)}$
- $M = \text{Moment}$
- $F = N$
- $M = Nm$
- $M/F = \text{distance center of pressure (x or y) is from the origin}$
- $M_x/F_z = \text{center of pressure coordinate along the y-axis}$

- M_y/F_z = center of pressure coordinate along the x-axis

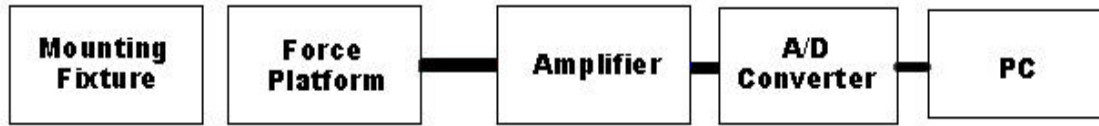

Figure 3: Force platform system.

In order to account for the primate both hanging and walking on its cage, the cage will have to be mounted atop the force platform.

The AMTI series force platforms can measure 1-6 channels of forces and moments and are available in 1000, 2000, and 4000 lb vertical capacities. The MC3A-6-1000 platform was chosen since it is the least expensive and well beyond the capacity of our tests (see figures 4 and Appendix A). This capacity will allow for the system to be reused for higher force producing tests (up to approx. 4450 N). Platform construction consists of strain gages mounted on precision strain elements, which require bridge excitation and amplification. AMTI’s amplifiers provide both excitation and amplification for the multiple channels. The DigiAmp (DSA-6) amplifier provides six digital or analog outputs, which makes the amplifier extremely versatile. The converter card’s 16-bit range also gives the amplifier high accuracy and dynamic range (See Appendix A for transducer and amplifier specifications). Data is finally interfaced with the computer via an Ethernet link. NetForce software takes the digital output directly from the a/d converter and outputs the data into an Excel file. The next two sections discuss the mechanical apparatus required for cage setup and also the software algorithms written to analyze the data.

Component	Description	Cost
NetForce Software	NetForce Software for Data Acquisition	\$1,500
MC3A-6-1000	Six Channel Multi-Component Force Transducer, 1000 lb capacity	\$3630
7615-015-2-2	15 feet of Cable with Standard Strain Connectors attached to Transducer and Amplifier Ends	\$145
DSA-6	6-Channel MiniAmp Signal Conditioner/Amplifier with digital or analog output.	\$5900
TOTAL		\$11,175

Table 1: Cost Analysis of System

Component	Description	Cost
Aluminum platform	3' x 2' x 1/2"	
16 Bolts and Nuts	3/16" x 1 1/2", 3/16" nuts	
4 Swing bolts	15 feet of Cable with Standard Strain Connectors attached to Transducer and Amplifier Ends	
8	6-Channel MiniAmp Signal Conditioner/Amplifier with digital or analog output.	
TOTAL		

Table 2: Cost Analysis of mounting apparatus.

MC3A

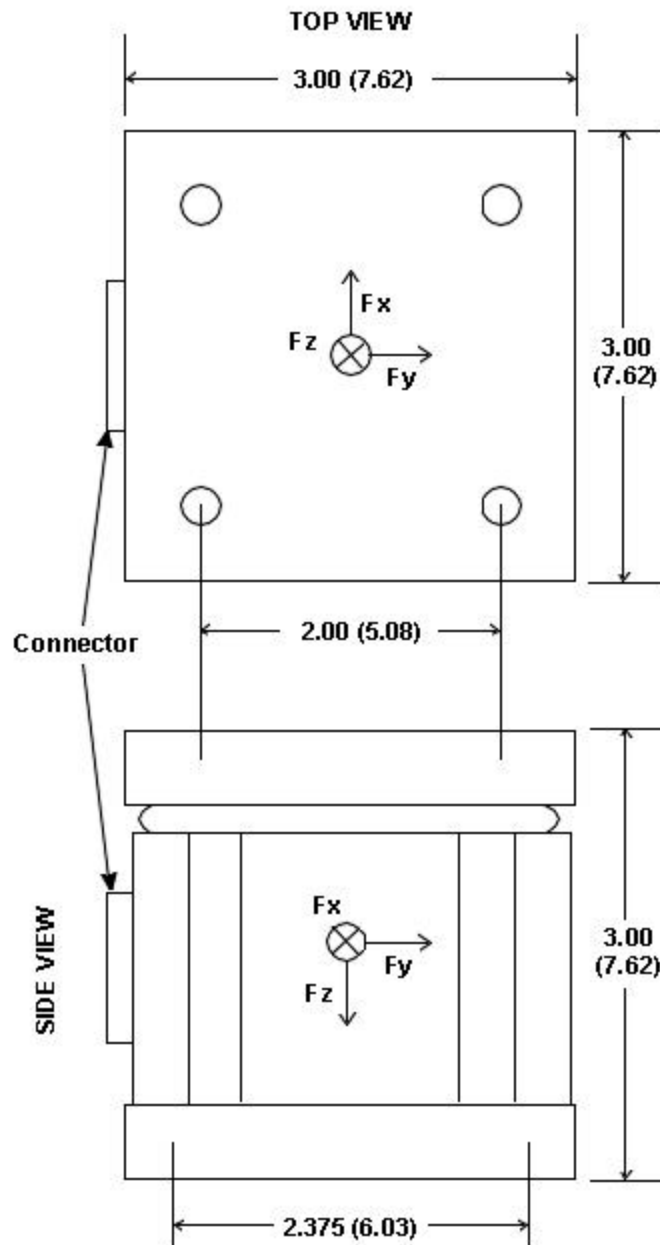

- All dimensions in inches (cm).
- Four threaded 1/4-20 inserts in 2 inch (5.08) centers on top surface.
- Four 0.256 inch (.676) through holes on 2.375 inch (6.03) centers on bottom surface.
- Metric threaded hold-down inserts available.

Fig. 4: Force platform

Mechanical Design/Mounting:

To get accurate results, the cage (Fig. 5, front view Fig. 6, side view Fig. 7) has to be secured to the force platform in such a manner that the cage and the force platform move as one. One-way to accomplish this is by bolting the cage on to the force platform. However, the size of the force platform (3' x 3') is much smaller than the size of the cage. To overcome that problem, we plan on mounting an extra sheet of metal on the top of the force platform with the dimensions of 2' x 3' x .5''.

All dimensions are in inches

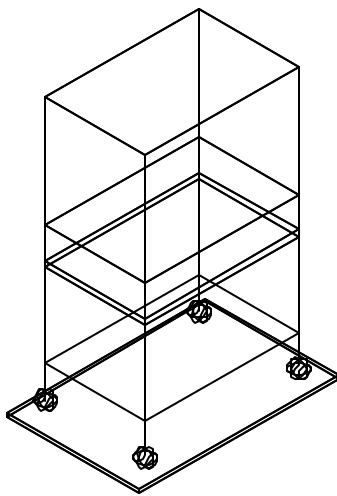

Fig. 5: 3-D view of Cage

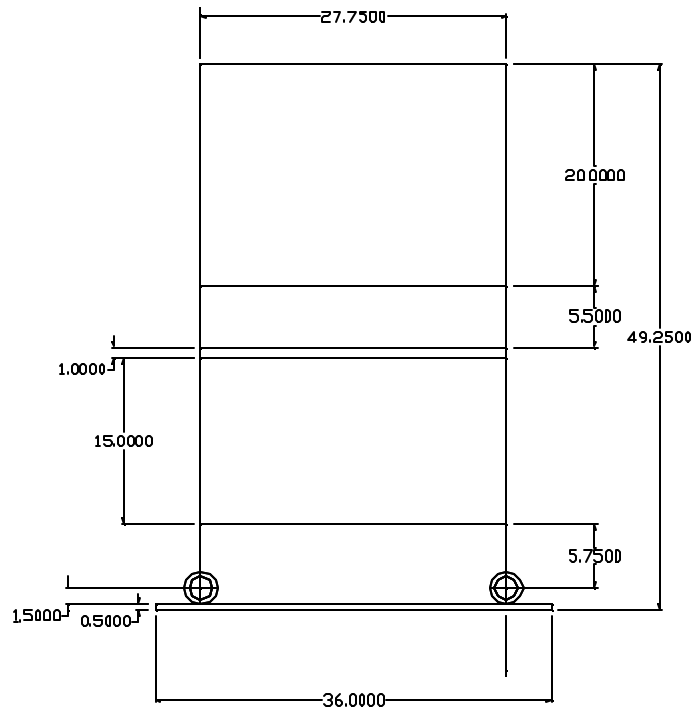

Fig. 6: Front view of cage

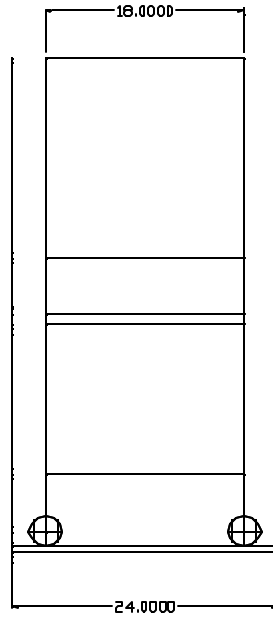

Fig. 7: Side view of cage

Four bolts and lock nuts will be used to hold the force plate and force platform. Eight angle braces, each on a corner, will be bolted on the top of the force platform. These braces will be used for the attachment of the swing bolts. The swing bolt swings up and is secured on the crossbar. The entire attachment apparatus is pictured in (fig. 8,9).

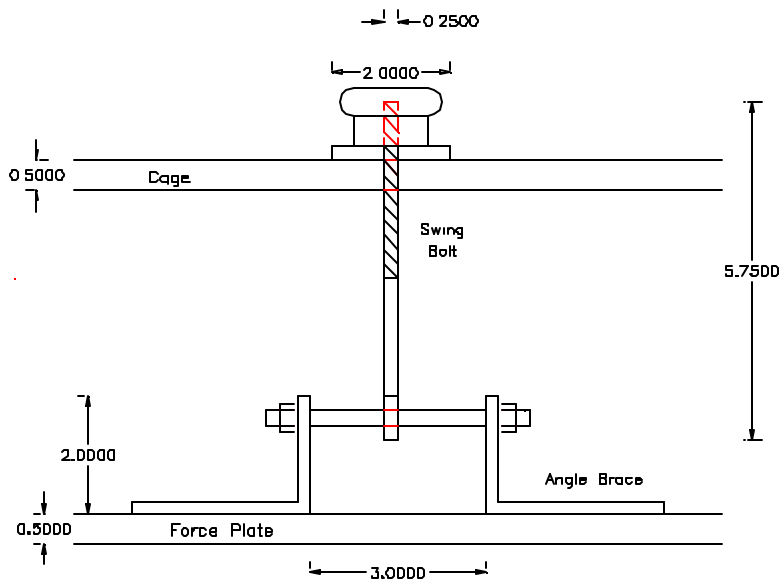

Fig. 8: Side view of attachment mechanism

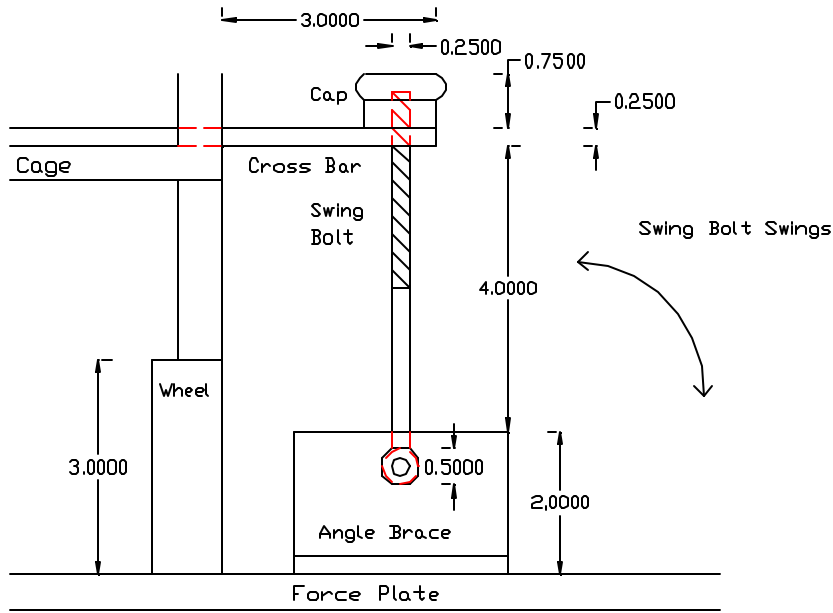

Fig. 9: Front view of attachment mechanism

The only modification of the cage is to add two metal bars to the cross bars which connect the legs of the cage. These metal bars will have a notch on each end, allowing the swing bolt to connect to the cage (fig 10).

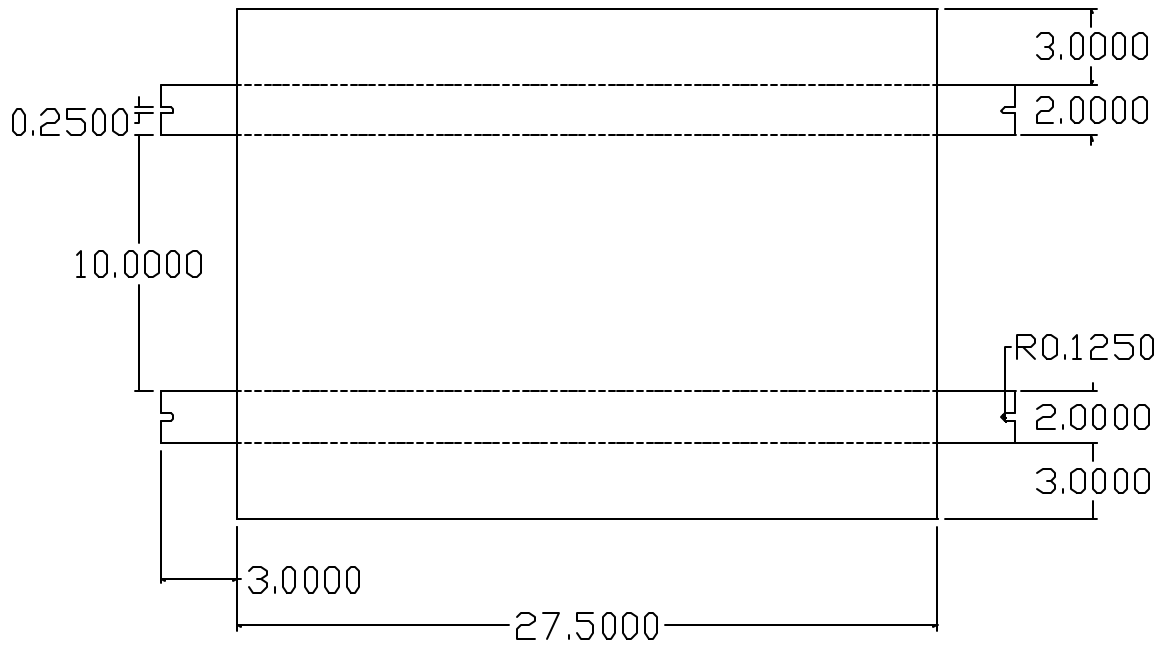

Fig. 10: Top view of cross attachment piece

To facilitate the mounting of the cage onto the force platform, we have designed a ramp system (fig. 11).

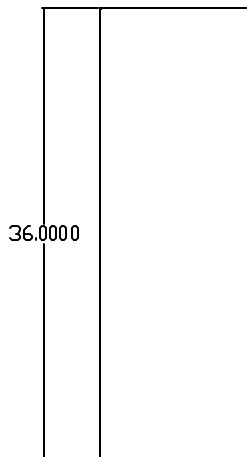
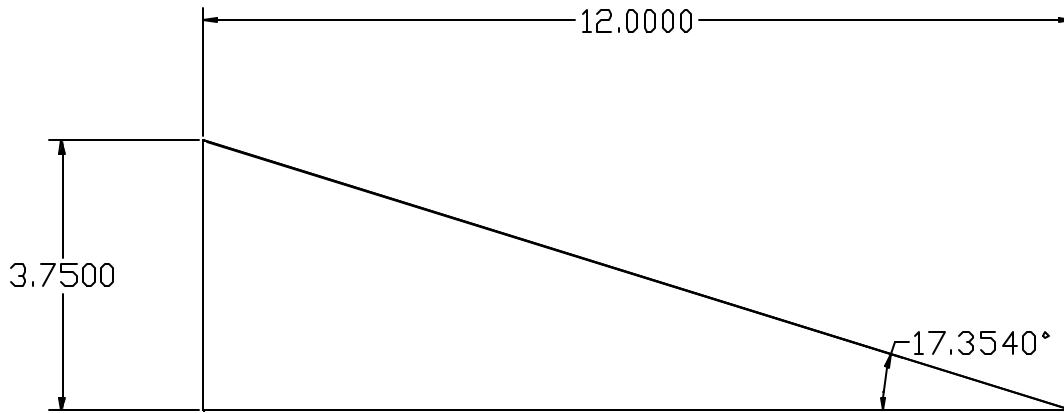

Fig. 11: Ramp to allow cage to roll onto platform

Software Design/Coding:

The software package we purchased with the force plate outputs data in the form of Excel files containing columns of values where each cell represents the force and moments exerted by the monkey at an instant in time. The samples are in units of counts, which are proportional to the voltage outputs of the strain gauges mounted in the platform. In order to convert counts to a more understandable measure of force and moments, the software also determines a calibration equation for the platform. Using this equation and the Excel files our team was left to convert the data and produce several graphs to better illustrate the results of the experiment. Also, in order to have some way to compare different experiments with each other a system of comparing trials had to be developed.

Because the data is contained within Excel files we originally decided that using solely Microsoft Visual Basic (VB) to manipulate the data would be the most effective because it has the ability to interface with Excel. This allows the sending of commands through Excel to the data, while using another language, such as Java, would require us to read in all the data, perform manipulations and finally output all the data back to a file. Using VB allows us to convert the data in its original file, simplifying things greatly.

First the data must be converted from counts to Newtons. To achieve this conversion, we constructed a VB application that graphs the user-specified calibration weights and count values to obtain the calibration equation. The equation is in the form $y = mx + b$, where m is equal to the number of counts per Newton, x is the count value to be plugged in, b is the number of counts when there is zero force being exerted on the platform and y is the converted force, acting on the platform along the z -axis, in Newtons.

Once the data is converted to the specified force(z) and the moments in the x and y direction, we plot the data to best understand the actions of the primate. To do so, the Visual Basic software we developed plots the given forces and moments against time. Force and moment plots quantify the magnitude of the primate's startle. In order to quantify the primate's movement of center of pressure, we also incorporated a function to plot the center of pressure in the x -direction versus the y -direction. Figure 12 – Figure 14 show the examples of various plots derived by the data analysis performed by the software. The data was optioned from a human subject in a previous sway analysis.

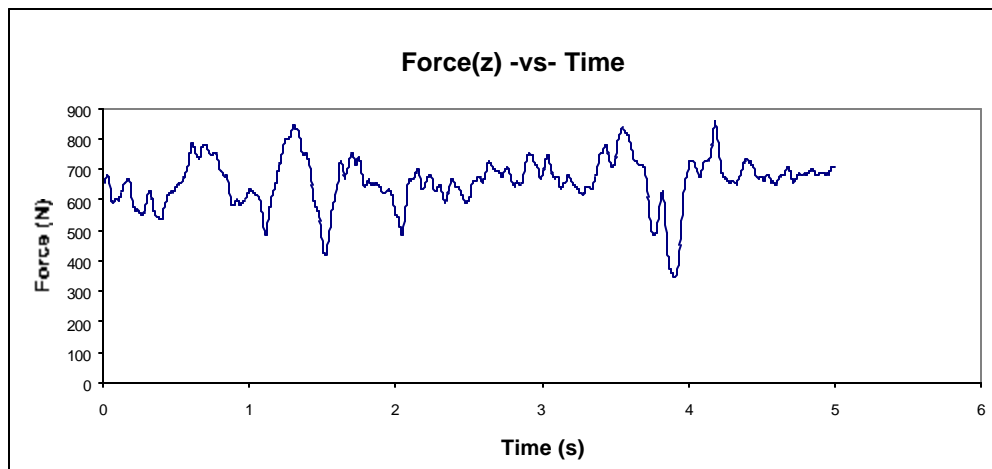

Figure 12: Force(z) exerted by a human versus time of the test.

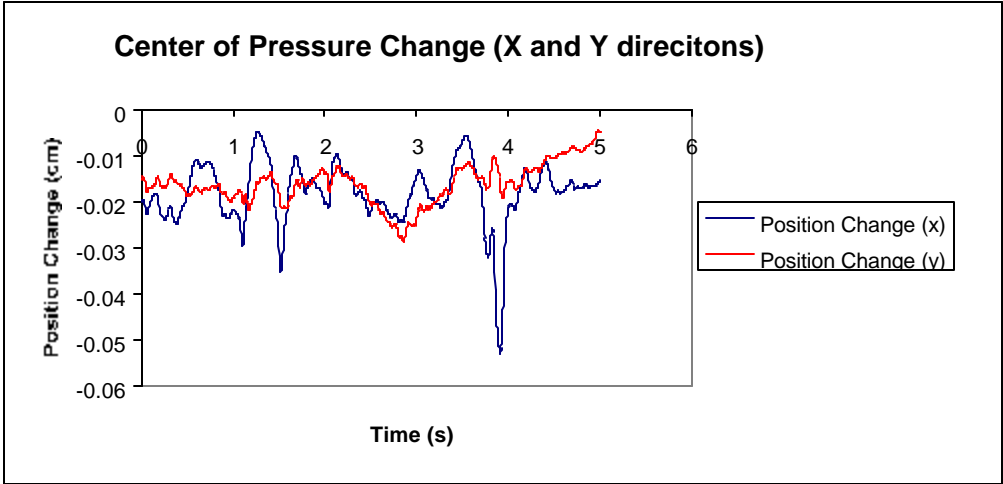

Figure 13: Moments in the $-x$ and $-y$ direction versus time of test

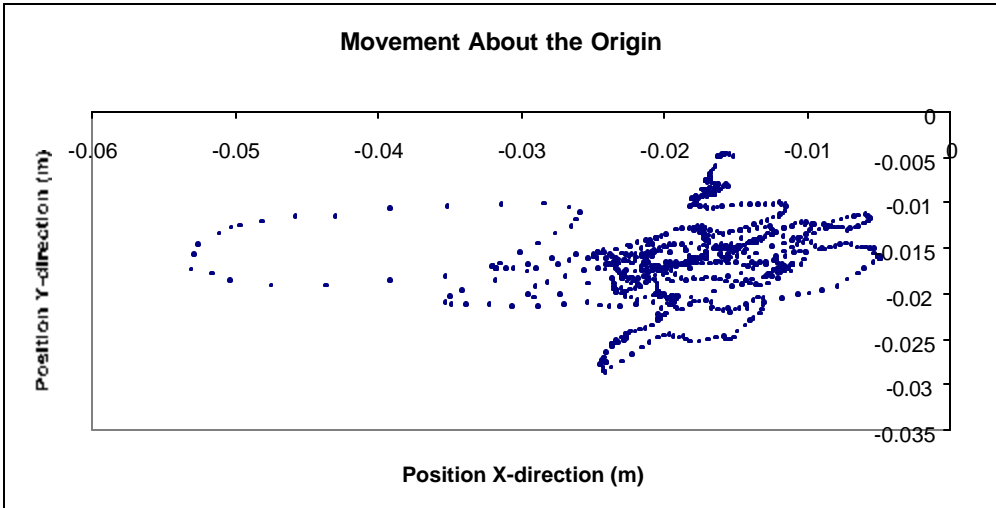

Figure 14: Position coordinates over test time (x and y coordinates)

Figures 15 – 17 show the user interface of the analysis software created with Visual Basic.

The Calibration dialog box features a blue title bar with the text "Calibration" and a close button. Below the title bar, there is a text input field labeled "Enter Sampling Frequency (Hz)". Underneath, there are two sections: "Fz Calibration" and "Moment Calibration". Each section contains two text input fields: "Enter Y-Intercept" and "Enter Slope". At the bottom of the dialog is a "Done" button.

Figure 15: Calibration equation information and sample frequency is collected through the text fields in this form. The user is prompted for the y-intercept and the slopes of both the force(z) calibration equation and the moments (x and y) calibration equation. When the user clicks “Done” they will be brought to the Graph Options menu shown in Figure 16.

The Graph Options dialog box has a blue title bar with the text "Graph Options" and a close button. It is divided into two main sections: "Plot Options" and "Plot Data". The "Plot Options" section contains three checkboxes: "Plot Fz", "Plot Center Of Pressure", and "Plot Change In Center Of Pressure". The "Plot Data" section contains two radio buttons: "Plot All Data Points" and "Plot Over Specific Time Interval". Below the radio buttons are two text input fields labeled "Enter Start Time (S)" and "Enter Stop Time (S)". A "Done" button is located at the bottom of the dialog.

Figure 16: User may choose from the three graphing functions above, force exerted by the primate in the z direction versus test time, center of pressure plot (overall movement), or changes in center of pressure versus test time. The user then decides whether they want to plot all data points or a specified range of points in the Plot Data menu. Once the user clicks “Done”, the specified graphs will be created and displayed in the open Excel file. They will then be displayed the form shown in Figure 12-14.

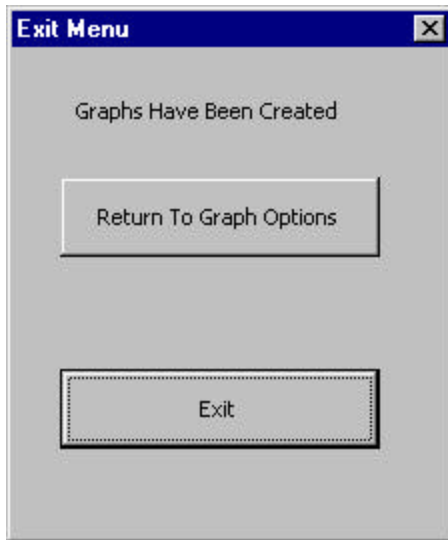

Figure 17: The Exit menu allows the user to return to the Graph Options menu shown in Figure 16 for further analysis. “Exit” shuts down the software package and returns to the open Excel page with the displayed graphs.

Future Software Development:

Currently, Java software is under development to allow the user to manipulate the data in order to get various text output. The user will be allowed to display forces in descending or ascending order, display average force values for the entire test, and also display force values for user specified time intervals. Another feature will allow the user to enter a force value to compare against, and then display all forces larger than that value. Similar options will be available for the moment values.

With many startle experiments being done the software will also eventually include a database to organize the data collected in each experiment. Possible implementations may include a binary search tree, which would allow for fast access of any experiment the researcher wished to go back and look at. This implementation would require a “key” value for each experiment or group of experiments. This key value is what the researcher would type in to search for an experiment. Possibilities include the date and time of day the experiment was conducted or the type of startle stimuli used. It depends on how the researchers wish to organize the data. There could also be several keys so a search could be run for an experiment performed at a certain time, or with a certain stimuli or any trait unique to the experiment.

Conclusion:

The final design allows the movements and forces of the monkey to be quantitatively recorded, allowing researchers to analyze the various effects caused by startling actions. This device will not only aid in quantifying movements, but will also help researchers understand how physical actions are related to chemical changes occurring within the monkey. In addition, the device allows the data to be recorded with significantly more.

Appendix A: AMTI force transducer and amplifier.

MSA-6 Force Transducer



(Figure ?: MC3A-1000 force platform)

MC3A SERIES SPECIFICATIONS	MC3A-X 1000
Fx, Fy Capacity, lb, (N)	500 (2224.1)
Fz Capacity, lb, (N)	1000 (4448.2)
Mx, My Capacity, in*lb, (Nm)	1000 (113)
Mz Capacity, in*lb, (Nm)	500 (56.5)
Fx, Fy Sensitivity, $\mu\text{V}/[\text{V}\cdot\text{lb}]$, ($\mu\text{V}/[\text{V}\cdot\text{N}]$)	3.0 (0.67)
Fz Sensitivity, $\mu\text{V}/[\text{V}\cdot\text{lb}]$, ($\mu\text{V}/[\text{V}\cdot\text{N}]$)	0.75 (0.17)
Mx, My Sensitivity, $\mu\text{V}/[\text{V}\cdot\text{in}\cdot\text{lb}]$, ($\mu\text{V}/[\text{V}\cdot\text{Nm}]$)	4.0 (35.4)
Mz Sensitivity, $\mu\text{V}/[\text{V}\cdot\text{in}\cdot\text{lb}]$, ($\mu\text{V}/[\text{V}\cdot\text{Nm}]$)	3.0 (26.6)
Fx, Fy Stiffness, $\text{X}10^5 \text{ lb/in}$, ($\text{X}10^7 \text{ N/m}$)	1.20 (2.17)
Fz Stiffness, $\text{X}10^5 \text{ lb/in}$, ($\text{X}10^7 \text{ N/m}$)	18.0 (32.68)
Mz Stiffness, $\text{X}10^4 \text{ in}\cdot\text{lb/radian}$, ($\text{X}10^4 \text{ Nm/radian}$)	20.0 (2.26)
Mx, My Natural Frequency, Hz	1000
Weight, lb, (Kg)	2.0 (0.9)

DSA-6 DigiAmp



DSA-6 SPECIFICATIONS
Gain: Computer or keypad selectable gains of 1000, 2000, 4000, and 8000.
Bridge Balance: Auto zero activated by keypad or PC command.
Excitation Range: Computer or keypad selectable 1/16th volt increments from 0 to 10 volts.
Selectable Digital Filters: Bessel or Butterworth filters pass through selectable 10, 20, 30, 50, 100, 200, 300, 500, or 1000 Hz cutoff frequencies.
Acquisition Rate: 96,000 samples per second (16,000 six-channel data sets per sec).
Outputs: ± 10 VDC
Stand-alone Interface: LCD and keypad
Network Interface: Ethernet to PC
Data Transmission: Ethernet, UDP Protocol
Power Supply: Desktop, triple output, IEC320 input, power supply.
Cable Length: Thin net - 500 ft maximum.
External Trigger: Digital level trigger
Interface Software: NetForce Software
Weight: 13 lbs (5.9 kg)

Mounting

Force Platform Mounting Instructions

INTRODUCTION

AMTI's Biomechanics Force Platforms measure the forces and moments applied to the surface of a platform. However, the accuracy of the data are dependent upon the quality of the mounting procedure. In all cases, the platform should be mounted in a manner that minimizes vibration and bending. While a simpler mounting system may be appropriate when *only* low frequency data is important, for optimal results, we recommend following the guidelines in this manual.

We suggest bolting the platform to a flat plate, which in turn is bonded to a solid foundation. A separate mounting plate is used due to its size, weight, dynamics and installation considerations. An example of a solid foundation would be a metal and concrete structure with a depth of 15-45cm (6-8") depending on the site, and the platform's application.

This manual provides an outline of the mounting procedure using AMTI's mounting fixtures. Keep in mind, this serves as a general outline. Each installation site is different and no single solution or suggestion is applicable to all situations. The intended use of the force platform often dictates the mounting procedure. For example, in static situations including postural and balance studies, the OR6-6 was designed to provide accurate results without a mounting plate.

If you should need further assistance regarding your specific mounting conditions, please [contact AMTI](#).

PLATFORM COORDINATE SYSTEM

All AMTI force platforms use the same coordinate axes convention. Figure 1 shows this convention with the origin referenced to the center of the top of the surface of the platform. In actuality, the origin lies a given x, y, and z offset from the center, as shown in the platform's calibration sheets. The positive z-axis points down on the plate, perpendicular to the cable connector. The positive y-axis points along the plate both away from and parallel to the connector. The x-axis direction is found using the y and z-axes and the right hand rule. [If you were to stand on the platform with your back to the connector, the positive x-axis points to the left.] The moments about the three axes also follow the right hand rule. [If you point your thumb in the positive direction for any of the axes, the fingers curl in the positive direction for the moment about that axis.]

GENERAL MOUNTING PRINCIPLES

The platform consists of a rigid top and a less rigid base connected by four sensing elements.

The sensing elements, located at the four corners of the platform, are comprised of foil strain gages attached to proprietary load cells. The gages form six Wheatstone bridges with four active arms that have eight or more gages per bridge. Three of the output channels are proportional to force, and three are proportional to moments. Under the following mounting conditions, these combined elements should work to provide accurate and reliable data.

1. **THE BASE OF THE PLATFORM MUST REMAIN RIGID** in comparison to the rigidity of the sensors and the top plate. This condition is critical for obtaining the components of the forces from the sensing elements used to calculate M_x and M_y , and thereby the center of pressure. A non rigid base will produce shifts in the measurements, resulting in an inaccurate performance of the platform. The use of metal plates does not necessarily produce an optimal installation. Ideally, we recommend a concrete floor on the basement level of a building. In short, all interfaces should be solid or linearly elastic in order to prevent non-linear effects.
2. **THE MOUNTING SURFACE MUST BE FLAT** to avoid erroneous stresses in the sensing elements. The platform should not rock when placed on the mounting surface. Un-machined hot rolled or cold rolled steel or aluminum are almost never flat enough to be used mounting surfaces. A flat surface can be defined as one on which a platform rests level to better than 0.5 mm (0.002"). If necessary, shims may be used. A machined surface should contact the force platform. This flat machined surface serves as an interface between the flat force platform and the uneven floor.
3. **AVOID VIBRATIONS** to eliminate external noise from the floor. Depending on the location of the site, this may be difficult to control. Floor mountings on the ground level of a new building are ideal. Upper floor installations should be located over support beams and near walls or support columns.

GENERAL MOUNTING INFORMATION

Figures 2, 3, 4, and 5 display the dimensions of the OR6-5, OR6-6, OR6-7 and LG6-4 platforms, in addition to the size and location of their mounting holes. We recommend using AMTI's SMF-1A for the OR6 series and the SMF-2A for the LG6-4 as part of your installation. The BP2416, BP2436, BP3216, BP3636, BP4848, BP5918, BP7116, and BP7124 have their own mounting plates. The mounting plates are 2.54 cm (1") thick precision-ground and anodized aluminum plates that provide both a flat surface, and a choice of mounting positions (figures 6 & 7). However, they simply provide an interface between the force plate and the floor. They are not designed to provide either the stiffness or the mass needed for a complete mount, unless they are bonded to a rigid surface such as a concrete floor. Often, structures such as steel welded frames are thought to be rigid but may be prone to vibrations that can affect the data.

We recommend using epoxy bonding agents to attach the mounting plate to the floor, and a thixotropic epoxy is provided by the factory with the plates. **For optimal results, clean and dry the surface to which you plan to apply the epoxy.** The epoxy, composed of a semisolid consistency, should fill (without overflowing) the entire gap between the mounting plate and the concrete. While the epoxy is curing, we suggest bolting the platform to the mounting plate to ensure that the plate cures flat with respect to the force platform.

The following mounting instructions are conservative and some experimentation is often necessary to determine the minimum acceptable performance.

MOUNTING INSTRUCTIONS

Choose a location and orientation of the platform(s).

Floor mountings on the ground level of a new building are ideal. Upper floor installations should be located over support beams and near walls or support columns. If installing the platform(s) in an existing building, place the mounting fixtures and platform(s) in the desired floor positions and test by collecting data before permanent installation.

Prepare a LEVEL foundation.

We suggest a minimum of a 15cm (6"), preferably 30 to 45cm (12 to 18"), of concrete foundation to provide a solid base for the platform. Leave clearance for the platform and the mounting plate, in addition to a 0.15cm (1/16") for the epoxy adhesive. In addition, leave at least 30cm (12") of clearance on the sides of the platform to tighten the mounting bolts and connect the cable once the platform is in place. For installations with less clearance, it is possible to tighten the nuts with a "crawfoot" wrench. If installing the platforms in a new building, work with the architect, engineers, and contractors to provide a substantial concrete base for the platform.

Prepare the mounting plate after the foundation is ready.

Install the set screws in the mounting plate by inserting them in the through-holes in the corners of the plate.

Insert the platform's mounting studs in the appropriate holes in the plate. Be certain that the studs are installed with the fine-threaded or turned down end up.

Check that the studs are in the correct holes by fitting the force platform over them. **DO NOT DROP THE FORCE PLATE!**

Remove the platform and place the mounting plate on the foundation.

Level the plate using the mounting screws. Place the platform on the plate to be certain that its position is correct.

Remove the platform and mark the position and orientation of the mounting plate.

Remove the mounting plate from the foundation.

Level the floor using epoxy (available through AMTI) and the mounting plate.

Please read and understand all instructions and MDS (material data sheets) before starting. Please refer any questions to AMTI.

Clean and dry the area to be leveled. Debris in the epoxy or on the floor can result in a surface with an uneven finish. Vacuum before laying down the epoxy.

Fill all small cracks with thixotropic epoxy (116T2 Kit supplied by AMTI) to contain the fluid epoxy. Uncured fluid epoxy will

leak out of small cracks. The 116T2 Kit has two parts that should be mixed thoroughly before applying. The thixotropic epoxy should be allowed to cure for 24 hours before adding the liquid epoxy.

Make sure the foundation and the mounting plate's bonding surface are clean and dry.

Find the amount of liquid epoxy needed. First, find the volume by measuring the floor area and multiplying by the average depth of the epoxy. Then use the conversion factor for all liquids. The conversion factor is 3785 cm³ (231 in³) per gallon. A one-quart epoxy kit is enough to fill approximately 0.25 cm (0.1") under the SMF-1A mounting plate.

Use the spatula to mix all of the epoxy together from the two pre-measured containers. Typically the resin is supplied in a five gallon pail, to which the smaller can may be added. A thorough mix should take 5-10 minutes. Scrape the sides of the container, and mix the bottom well.

After the first kit is mixed, spread it thickly and evenly over the foundation. Cover the area that holds the mounting plate, and/or spread epoxy on the bottom of the mounting plate.

If the finished height of the cured epoxy with respect to the finished floor is very critical, some reference measurement of the epoxy surface will have to be made relative to the finished floor. The epoxy may take 30 minutes to level itself, and therefore the measurement should take this into account. It is easier to add epoxy than it is to remove it.

For more than five gallons of epoxy, mix the containers separately. After pouring the first batch into the pit, begin to prepare the second batch.

Place the mounting fixture on the foundation in the same position previously marked. The epoxy will squeeze out slowly until the leveling screws are sitting on the foundation. When the plate is in position, there should not be any voids between the floor and the plate.

Let the resin cure at 21° C (70° F). After two days, the resin will cure 80%. To cure 100%, one must wait one to two weeks. **DO NOT PLACE LOADS ON THE SURFACE UNTIL IT IS FULLY CURED.**

Attach the platform to the mounting plate.

Clean the top surface of the mounting fixture.

Place the platform on the mounting fixture and use washers and nuts to bolt the platform down. The nuts should be

tightened with a wrench, but the actual torque used to tighten the nuts is not critical.

For the LG6-4, BP3216, BP2436, BP 3636, BP4848, BP5918, BP7116, and BP7124: Install the sixteen mounting studs by inserting them in the holes in each of the four load cell mounting pads located on the bottom of the platform.

For the OR6 series and the BP2416: Be certain to *leave a gap between the top of the mounting stud, and the top of the force platform*. Otherwise, the top of the platform will not move freely, and erroneous stresses may appear in the data

Connect the cable to the platform.

Complete the rest of the installation. Leave a small gap on all sides of the platform so that the top can move freely. Nothing should touch the sides of the top plate.

SPECIFICATIONS

FOR THE LG6-4, BP3216, BP2436, BP 3636, BP4848, BP5918, BP7116, & BP7124

The SMF-2A mounting fixture for the LG6-4 is 57.2 by 77.5 cm (22.5 by 30.5 inches) and 2.54 cm (1") high (figure 4). If the platform's surface is to be level with the floor, the foundation's surface should be slightly more than 18.42 cm (7.25") below floor level, in addition to clearance for the epoxy adhesive. There are four set screws, and sixteen platform mounting studs.

FOR THE OR6 SERIES AND THE BP2416

The SMF-1A mounting fixture is 52.7 by 57.15 cm (20.75 by 22.5 inches) and 2.54 cm (1") high (figure 6). The BP2416-SMF is 66.3 by 40 cm (26.12 by 18.25 inches) and 2.54 cm (1") high (figure 7). If the platform's surface is to be level with the floor, the foundation's surface should be slightly more than 11.12 cm (4.375") below floor level, in addition to clearance for the epoxy adhesive. There are four set screws, and four platform mounting studs.

MOUNTING MORE THAN ONE PLATFORM

Figure 8 illustrates possible orientations to mount more than one platform. Note that the distance between the plates is the minimum designed to allow for cable clearance. Your specific application will determine the distance between your plates. For example, the distance will be different if studying pediatric gait rather than running in elite athletes. The most common way to mount two plates is shown in figure 8a. However, *when positioning two or more plates, the sign convention for the coordinate axes must be taken into account*. SEE PLATFORM COORDINATE SYSTEM.

MOUNTING THE OR-6 ON THE SMF-4A TRANSPORTABLE FIXTURE

The top plate of the SMF-4A of the mounting fixture has the same platform mounting locations as the SMF-1A. Figure 9 shows the dimensions of the SMF-4A, in addition to a corner of the fixture with its leveling screw and platform stud. Follow the steps from above omitting sections B and D.

DESIGNING AND CONSTRUCTING YOUR OWN MOUNTING FIXTURE

You may wish to design and construct your own mounting system. The details of the design depend, on your requirements, but all mounting systems share common features. For these features, refer back to GENERAL MOUNTING PRINCIPLES, and GENERAL MOUNTING INFORMATION. For custom designs, consult a qualified structural engineer or AMTI.

AIR-BEARING MOUNTING SYSTEM

AMTI force plates are easily moved across a level surface using AMTI's air bearing mounting system, allowing repositioning of the plates for different biomechanics tests. Pressurized air, supplied by a blower, raises the mounting fixture slightly so it can be moved to a new position. When the blower is turned off, the force plate assembly rests on the floor and provides the stiffness needed for high quality data. Once the force plate assembly is in the proper location, bracing blocks hold the force platform in position. When the platform is to be moved again, the blocks are removed and the air supply is reconnected so the platform can be repositioned easily.

The force plates can be moved anywhere on a prepared surface. The surface has an epoxy covering so it is flat and smooth. The surface could be in a mounting pit for the platforms, so they are flush with the surrounding floor, or it could be a portion of the floor surrounded by raised flooring.

The mounting plates, air supply, and leveling epoxy are available from AMTI. The floor and bracing blocks are provided by the customer.

The general installation procedure for the air-bearing mounting system is:

Prepare a flat, concrete surface, level within 3mm (1/8"), and allow it to cure for 30 days. An OR6 platform and air-bearing support is approximately 25 cm (10.25") high.

Clean and vacuum the surface, removing all debris.

Pour epoxy resin over the surface and allow it to cure.

Place the mounting plate over the surface, and attach the force platform.

Install the surrounding floor, using bracing blocks to prevent the plate from slipping sideways.

The procedure for moving the force platform is:

Remove the flooring and connect the air supply.

Turn on the air supply, move the platform, turn off the air.

Disconnect the air supply and replace the flooring.

The mounting system requires:

AMTI SMF-3A (for OR6 force platforms) or SMF-5A (for LG6 force platforms) air bearing mounting fixture.

AMTI HVLP air supply and connecting hose.

AMTI Resin kit (specify kit size).

Surrounding flooring and bracing blocks

THE AIR-BEARING MOVABLE MOUNTING PLATE (SMF-3A AND SMF-5A)

The SMF-3A is a movable mounting base for use with the OR6 series platforms. It is a modified version of the SMF-4A mounting plate incorporating air bearing features. The overall height of the SMF-3A is 10.2 cm (4") and it provides sufficient stiffness for the best force platform performance without epoxy bonding to the floor. It is made of anodized aluminum and weighs approximately 79 Kg (170 lbs).

The "air bearing" feature has been included in the design to facilitate moving the mounted platform over a designated area. The air bearing effect is obtained by passing a large volume of low pressure air through passages machined into the SMF-3A. The air escapes out of the bottom of the mounting base and lifts it a small distance (0.01 cm, 0.04"). The mount and platform float on the cushion of air and they may be effortlessly moved across a specially prepared floor.

The SMF-3A may also be installed without utilizing the air bearing feature. Figure 10 shows a typical installation for an SMF-3A or SMF-4A with leveling feet on a typical floor. The leveling feet are not necessary if the mounting surface for the SMF-3A or SMF-4A is very flat. A technique has been to easily provide a surface which is flat and level to better than 0.01 cm (0.004") over an arbitrarily large area. This degree of flatness is required to make use of the air bearing feature of the SMF-3A.

The flat surface is obtained by simply pouring a layer of liquid epoxy over a clean dry floor and allowing it to level out and cure. An appropriate "dam" is required to keep the epoxy from flowing out of the desired area. An epoxy layer 0.25 cm (0.1 inch) thick over a 122 cm (4 foot) square area requires one gallon of epoxy. Larger areas or thicker layers require more epoxy.

AMTI can supply the epoxy for the installation (Part # RESIN-828500)

A small air turbine (Model HVLP), available from AMTI, provides 40 cfm at 4psi for moving the SMF-3A. It connects to the SMF-3A with a short flexible hose.

Leveling feet are not required with an epoxy leveled floor, but some method should be used to prevent lateral movement of the mounting base if large side forces are expected. Blocking the mounting base against the surrounding floor structure is one technique.

A similar air bearing mounting plate is available for the LG6-4 platform. The model SMF-5A is 10.2 cm (4 inches) thick and is 61 X 122 cm (24 X 48 inches) in size.

WARNING STATEMENTS

AMTI Biomechanics Force Platforms are intended for use only with AMTI SGA/MCA model amplifiers

- 1. DO NOT DROP THE FORCE PLATFORM.** Extremely high impulse forces will **damage the force platform**. When handled correctly, the platform should provide years of trouble-free operation. However, due to its mass, dropping the force platform (even a short distance) may exceed forces out of the platform's safe range. Electrical safety systems may be compromised in the event of a damaged or deformed sensor element. If damage is suspected, Contact qualified personnel.
- 2. A PAIL OF MIXED RESIN/HARDNER SHOULD NOT SIT MORE THAN ½ HR.** An exothermic reaction occurs while the epoxy cures. Therefore **it will become extremely hot & may emit smoke**.
- 3. DO NOT TAMPER WITH THE SOCKET HEAD CAP SCREWS** visible at the bottom of the LG6-4, BP3216, BP2436, BP 3636, BP4848, BP5918, BP7116, and BP7124. You may

damage the strain elements. If additional holes are required on any surfaces, advice should be obtained from AMTI (Advanced Mechanical Technology, Inc.)

4. **DO NOT REMOVE THE INPUT/OUTPUT PLUG** without instruction from AMTI. If modifications are needed, obtain advice from AMTI (Advanced Mechanical Technology, Inc.)

SAFE LOADS

In some cases, you may be able to exceed the capacity of the platform and still be in the safe operating range. The maximum safe loading which can be applied to the platform is dependent upon the combined stresses imposed on the sensing elements by each force component. There is therefore no single maximum safe load. If a specified load capacity above the limits is required, the factory should be contacted.

The first piece of evidence of serious overload will be a significant zero shift. This may not indicate permanent damage. The platform may simply need recalibration.

OPERATING ENVIRONMENT

The platform and amplifier system is intended to operate within the following limitations.

Installation	2
Pollution Degree	1
Altitude	0-2000 Meters
Temperature	5° -40° C
Humidity	0% to 80%
Voltage Fluctuation	± 10%
Transport & Storage	Retain in original crate at above conditions

accuracy and repeatability, than the current method of having undergraduates observe and record the monkeys' movements.