

HW #1-SOLUTIONS TO SELECTED PROBLEMS

If you have questions on other problems please see the course teaching assistant or instructor.

4. (10 points) Memory Construction

Use SN74LVTH574 and SN74LVC1G139 devices to create a 4 x 16b SRAM. Obtain datasheets for them from Texas Instruments, Inc. Your circuit should have the following external connections; A1:0, D15:0, Q15:0, /WR, /RD. You may draw the schematic by hand (neatly), or use one of the many CAD programs available. Use the minimum number of devices and additional gates to complete the circuit.

Since we have 2-bit addresses, we can control $2^2 = 4$, 8-bit registers (SN74LVTH574). To control data reading and writing into the registers, we use the CP (Clock Pulse) for writing and the OE (Output Enable) for reading. In order to read or write from only one register at any given time, we use a decoder (SN74LVC1G139) for these two functions. Since the decoders don't have an enable input (thus one output is always active low), we must externally gate the decoder outputs with the /RD or /WR lines. The diagram is as shown below:

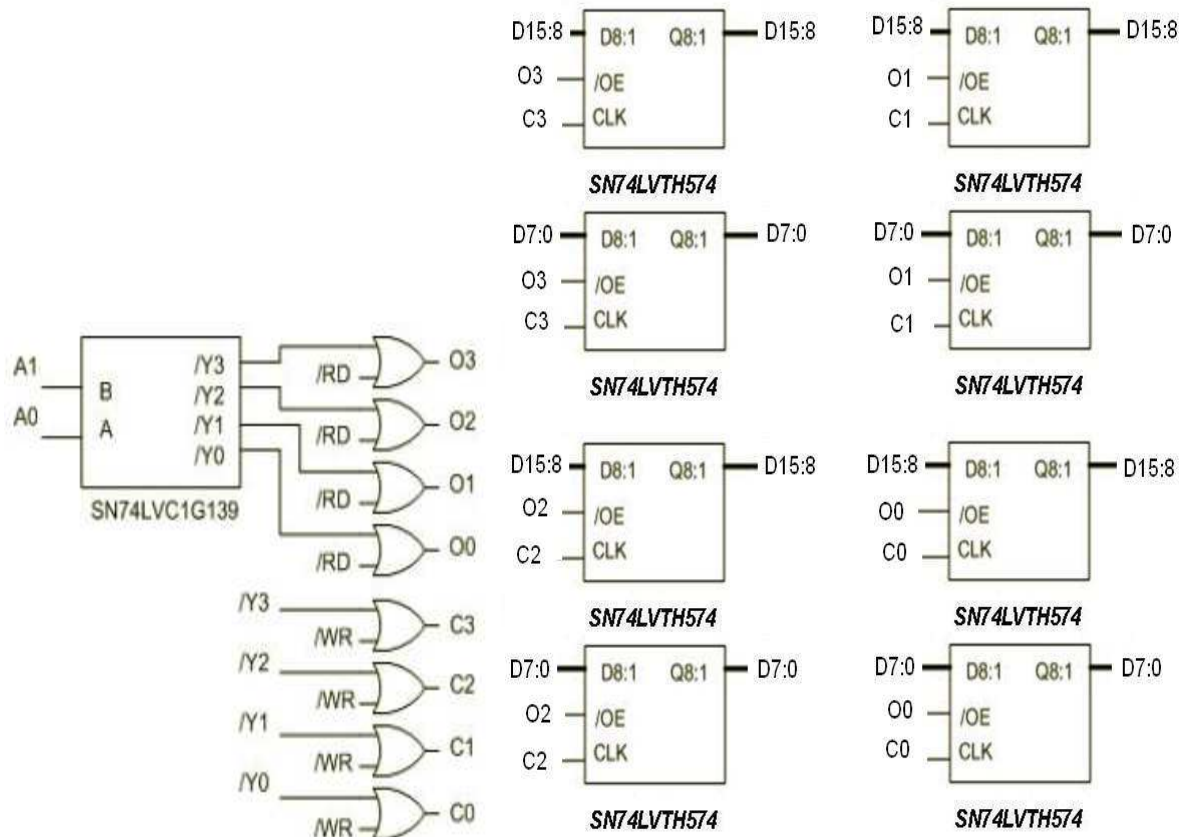

5. (15 points) Memory Operation

A. For the circuit you designed in #4 above, draw the waveforms (\overline{WR} , \overline{RD} , A_x , D_x) that would be required to perform the following sequence of operations. Also show Q_x . Assume 3.3V operation.

- 1) write the value 0x0F80 into the register at address 3
- 2) read the value in the register at address 3
- 3) write the value 0x12A5 into the register at address 2
- 4) read the value in the register at address 2

Ensure that any expected or required signal delays are made obvious on your diagram. Annotate your drawing to clearly indicate what is happening.

For write operations, the data bus needs to be driven before the write strobe takes place, and then held until after rising edge of the write strobe. For read operation, there will be a delay between the read strobe assertion and the data output. The waveforms are shown below and assume that the registers are numbered 0-3. Logic high is 3.3V. Logic low is 0V.

